

## BCT Series - Cast iron frame three phase low voltage electric motor

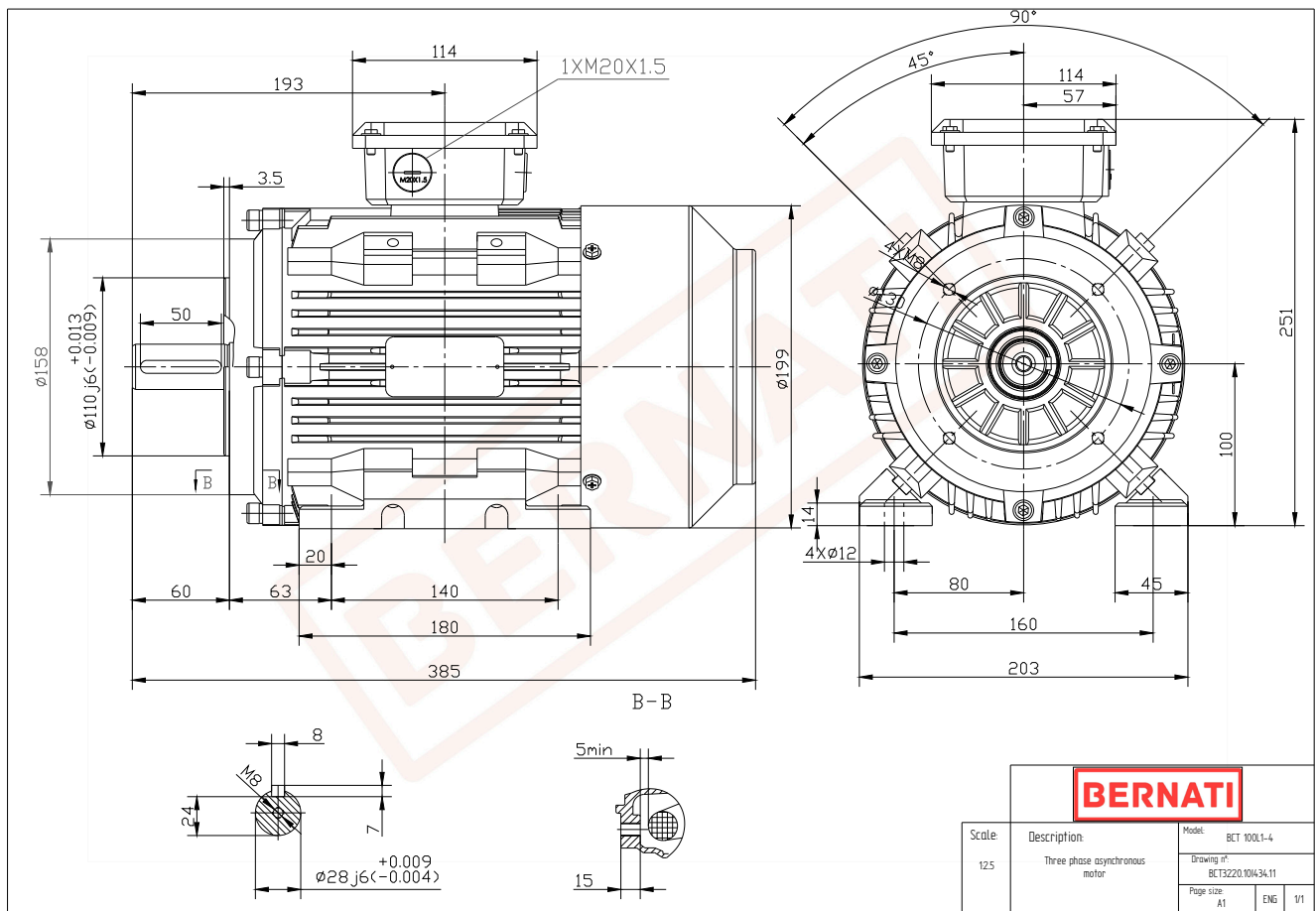

### BCT

Product Code	BCT3220.10/434.11
Motor Type/Frame	BCT 100L1-4
Mounting	IM B3/B14
Efficiency Class	IE3
Output Power (kW)	2.20
Speed (rpm)	1430
Tension (V)	230/400
Frequency (Hz)	50
Current (A)	4.50
Power factor (Cos Ø)	0.80
Poles	4
Insulation Class	F
IP Class	IP55
50% Efficiency	85.2
75% Efficiency	87.8
100% Efficiency	86.7
Torque (Nm)	14.70
Tstart / Tnominal	2.80
Istart / Inominal	8.00
Tmax / Tnominal	3.00
Noise (dB)	64
PTC Thermistor	PTC 130
Weight (Kg)	36
DE Bearing	6206 2RZ C3
NDE Bearing	6206 2RZ C3