

# Technical Datasheet

**BERNATI**

BCT Series - Cast iron frame three phase low voltage electric motor

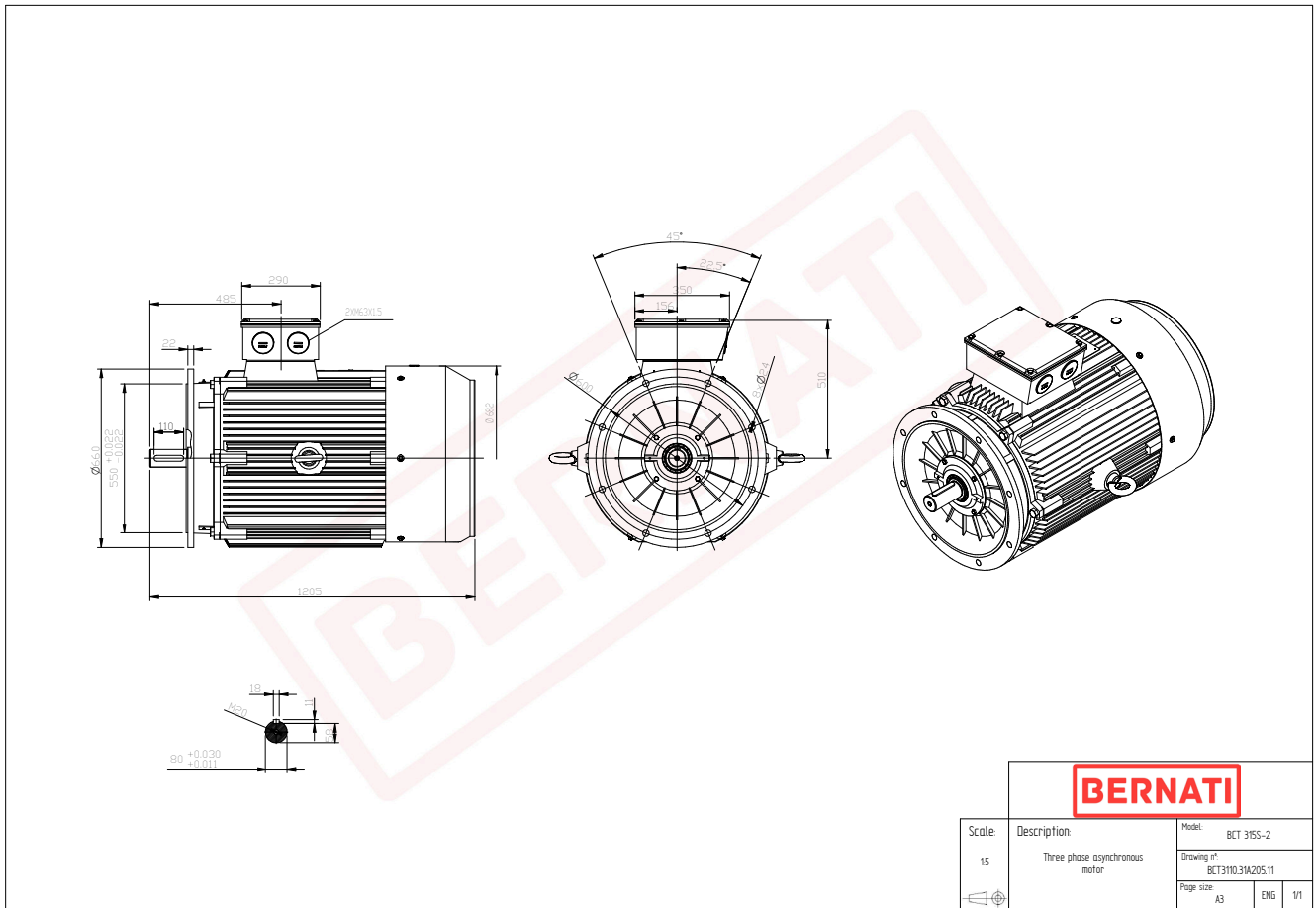

<b>BERNATI</b>	
Scale: 1:5	Description: Three phase asynchronous motor
Model: BCT 315S-2	Drawing n°: BCT3110.31A205.11
Page size: A3	ENG 1/1

## BCT

Product Code	BCT3110.31A205.11
Motor Type/Frame	BCT 315S-2
Mounting	IM B5
Efficiency Class	IE3
Output Power (kW)	110.00
Speed (rpm)	2960
Tension (V)	230/400
Frequency (Hz)	50
Current (A)	185.30
Power factor (Cos Ø)	0.90
Poles	2
Insulation Class	F
IP Class	IP55
50% Efficiency	94.6
75% Efficiency	95.5
100% Efficiency	95.2
Torque (Nm)	355.90
Tstart / Tnominal	2.00
Istart / Inominal	7.00
Tmax / Tnominal	2.30
Noise (dB)	96
PTC Thermistor	PTC 130
Weight (Kg)	980
DE Bearing	6317 C3
NDE Bearing	6317 C3