

# Technical Datasheet

**BERNATI**

BCT Series - Cast iron frame three phase low voltage electric motor

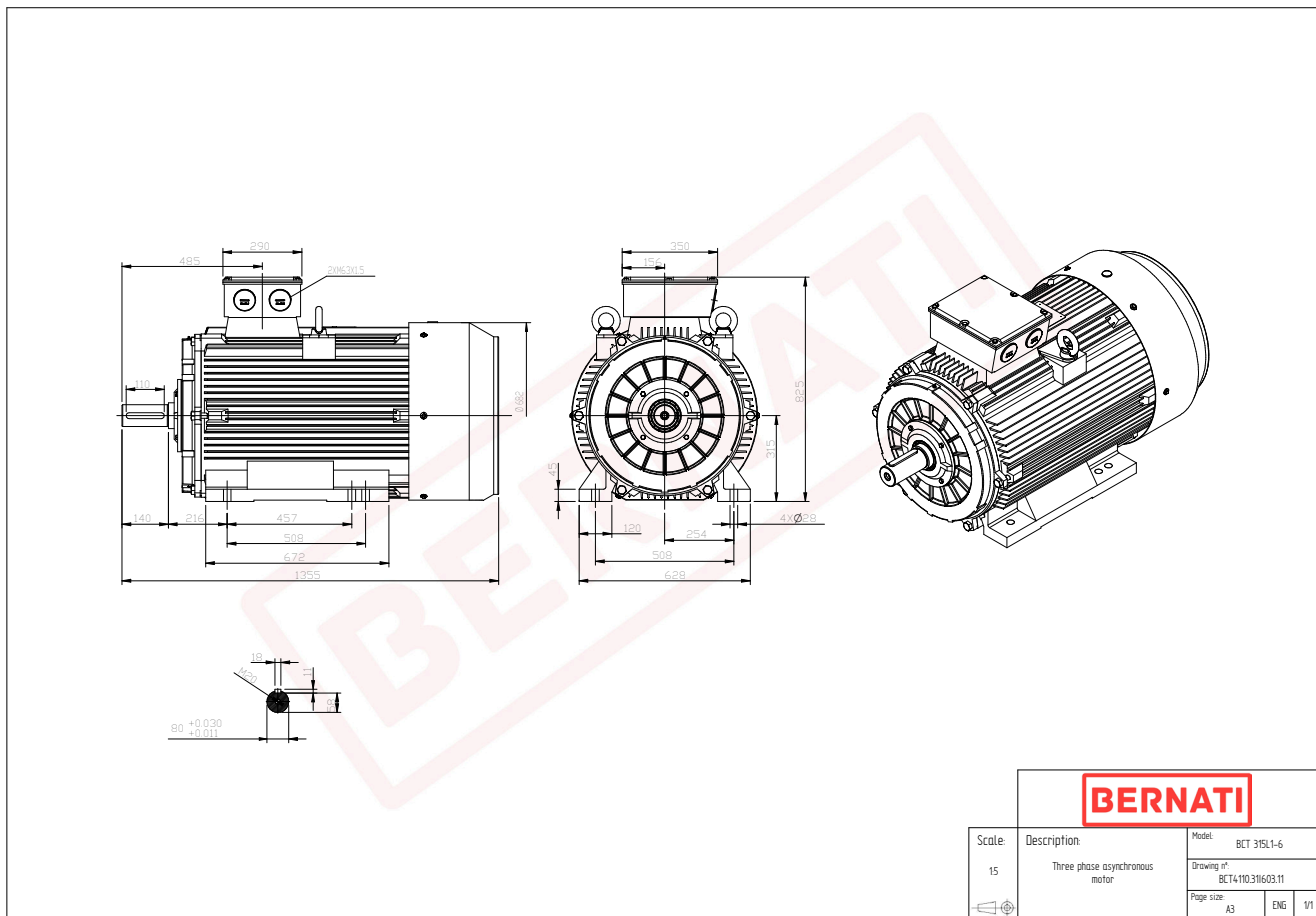

## BCT

Product Code	BCT4110.31603.11
Motor Type/Frame	BCT 315L1-6
Mounting	IM B3
Efficiency Class	IE4
Output Power (kW)	110.00
Speed (rpm)	990
Tension (V)	230/400
Frequency (Hz)	50
Current (A)	195.00
Power factor (Cos Ø)	0.90
Poles	6
Insulation Class	F
IP Class	IP55
50% Efficiency	95.6
75% Efficiency	96.0
100% Efficiency	95.8
Torque (Nm)	1061.60
Tstart / Tnominal	1.60
Istart / Inominal	8.00
Tmax / Tnominal	2.00
Noise (dB)	83
PTC Thermistor	PTC 130
Weight (Kg)	1277
DE Bearing	NU319
NDE Bearing	6319 C3